

**Status Report – 4S (Toshiba Energy Systems & Solutions Corp./Japan)**  
**DATE (2019/October/28)**

This reactor design is an evolution from the previous 4S which is described in ARIS Status Report [<https://aris.iaea.org/PDF/4S.pdf>]

The reference plant is the 10MWe-4S and has a power output of 10 MWe.

**INTRODUCTION**

**Indicate which booklet(s):** [<https://aris.iaea.org/Publications/SMR-Book 2018.pdf>]  
**Large WCR** [  ] **SMR** [  ] **FR**

The 4S (super-safe, small and simple) is a small sodium-cooled pool-type fast reactor with metal fuel. Being developed as distributed energy source for multi-purpose applications, the 4S offers two outputs of 30 MWth or 10 MWe and 135 MWth or 50 MWe, respectively. 4S reactor cores are designed to have a lifetime of 30 years for the 30 MWth core and 10 years for the 135 MWth core. These power outputs are selected from the demand analyses. The 4S is not a breeder reactor since the blanket fuel, usually consisting of depleted uranium located around the core to absorb leakage neutrons from the core to achieve breeding of fissile materials, is not present in its basic design. The non-refueling reactor core for 30 years is made by reflector controlled metallic core. The hybrid system by combining the 4S and Smart Grid and Energy Storage System by hydrogen is planned to bring more flexibility and broad application and to harmonize with renewable energy system. In this booklet, the design status on the 10MWe-4S is described below.

**Development Milestones**

- 1988 Began conceptual design study in Toshiba.
- 1991 IAEA seawater desalination study in CRIEPI
- 2002 Innovative technology development funded by MEXT started.
- 2006 Innovative technology development funded by MEXT finished.
- 2006 White paper for 4S introduction issued by Galena, Araska
- 2008 Pre-application (Phase1): USNRC Public meetings finished.
- 2008 Pre-application (Phase2): Submission of the technical reports to USNRC.
- 2013 Pre-application (Phase2): Submission of the 18 technical reports to USNRC completed.

**Target schedule after pre-application is as follows.**



\*) Year after start of licensing

Toshiba Energy Systems & Solutions Corporation (e-mail: [kazuhito1.asano@toshiba.co.jp](mailto:kazuhito1.asano@toshiba.co.jp))

**Links (www...) to:**

Detailed Design Description:

“4S Design description” submitted to NRC ,

<https://adamswebsearch2.nrc.gov/webSearch2/main.jsp?AccessionNumber=ML081440765>

Licensing Application Support Documents:

- (1) ML072950025, “First Meeting with NRC Pre-Application Review”, October 23, 2007.  
<https://adamswebsearch2.nrc.gov/webSearch2/main.jsp?AccessionNumber=ML072950025>
- (2) ML080510370, “Second Meeting with NRC Pre-Application Review”, February 21, 2008.  
<https://adamswebsearch2.nrc.gov/webSearch2/main.jsp?AccessionNumber=ML080510370>
- (3) ML081400095, “Third Pre-Application Review Meeting with NRC”, May 21, 2008.  
<https://adamswebsearch2.nrc.gov/webSearch2/main.jsp?AccessionNumber=ML081400095>
- (4) ML082190834, “Fourth Pre-Application Review Meeting with NRC”, August 8, 2008.  
<https://adamswebsearch2.nrc.gov/webSearch2/main.jsp?AccessionNumber=ML082190834>
- (5) ML081440765, “4S Design Description”, May, 2008.  
<https://adamswebsearch2.nrc.gov/webSearch2/main.jsp?AccessionNumber=ML081440765>
- (6) ML082050556, “LONG-LIFE METALLIC FUEL FOR THE SUPER SAFE, SMALL AND SIMPLE (4S) REACTOR”, June, 2008.  
<https://adamswebsearch2.nrc.gov/webSearch2/main.jsp?AccessionNumber=ML082050556>
- (7) ML090650235, “4S Seismic Base Isolation Design Description”, February, 2009.  
<https://adamswebsearch2.nrc.gov/webSearch2/main.jsp?AccessionNumber=ML090650235>
- (8) ML092170507, “4S Safety Analysis”, July, 2009.  
<https://adamswebsearch2.nrc.gov/webSearch2/main.jsp?AccessionNumber=ML092170507>
- (9) ML101400662, “Phenomena Identification and Ranking Tables (PIRTs) for the 4S and Further Investigation Program”, May, 2010.  
<https://adamswebsearch2.nrc.gov/webSearch2/main.jsp?AccessionNumber=ML101400662>
- (10) ML102940207, 4S Response to 73 FR 60612, “Policy Statement on the Regulation and Advanced Reactors” and SECY-10-00034, “Potential Policy, Licensing, and Key Technical Issues for Small Modular Nuclear Reactor Designs”, October, 2010.  
<https://adamswebsearch2.nrc.gov/webSearch2/main.jsp?AccessionNumber=ML102940207>
- (11) ML11277A236, Submittal of Technical Report "4S Core Nuclear Design Codes and Methods Validation", September, 2011.  
<https://adamswebsearch2.nrc.gov/webSearch2/main.jsp?AccessionNumber=ML11277A236>
- (12) ML11277A234, Submittal of Technical Report "Evaluation for 4S Emergency Planning Zone", September, 2011.  
<https://adamswebsearch2.nrc.gov/webSearch2/main.jsp?AccessionNumber=ML11277A234>
- (13) ML121290607, "Phenomena Identification and Ranking Tables for 4S Beyond-Design-Basis Accidents - Local Faults and Sodium-Water Reaction", April, 2012.  
<https://adamswebsearch2.nrc.gov/webSearch2/main.jsp?AccessionNumber=ML121290607>
- (14) ML13037A423, “Aircraft Impact Assessment for 4S”, AFT-2011-000254 Rev003, August, 2012.  
<https://adamswebsearch2.nrc.gov/webSearch2/main.jsp?AccessionNumber=ML13037A423>
- (15) ML12278A087, "Validation of 4S Safety Analysis Code SAEMKON for Loss of Offsite Power Event", September, 2012.  
<https://adamswebsearch2.nrc.gov/webSearch2/main.jsp?AccessionNumber=ML12278A087>
- (16) ML12296A022, AFT-2012-000230 Revision 000, “Prevention of Severe Accidents for 4S”, September, 2012.  
<https://adamswebsearch2.nrc.gov/webSearch2/main.jsp?AccessionNumber=ML12296A022>

(17)ML13070A347, AFT-2012-000241 Rev. 002, "Design Description of the 4S Instrumentation and Control System", February, 2013.  
<https://adamswebsearch2.nrc.gov/webSearch2/main.jsp?AccessionNumber=ML13070A347>

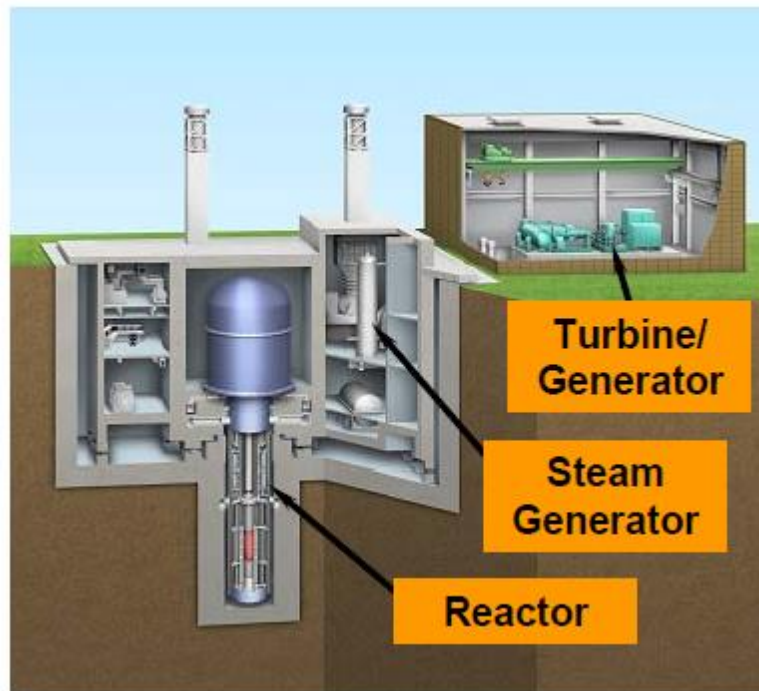

Figure 1 4S Plant Configuration

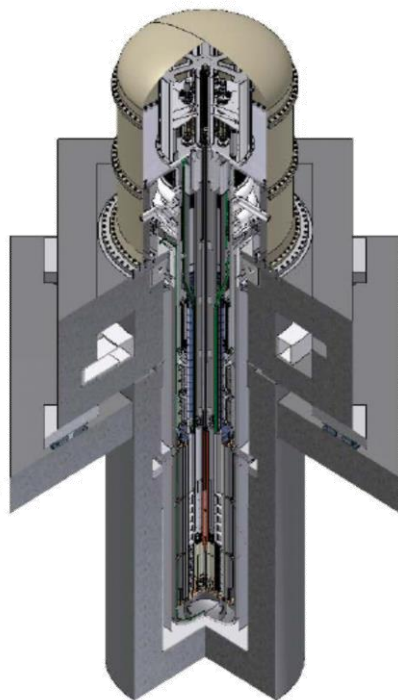

Figure 2 Reactor System Configurations

**Table 1: ARIS Category Fields (see also Spreadsheet “Categories”) for Booklet**

ARIS Category	Input	Select from
Current/Intended Purpose	Commercial – Electric and non-electric	Commercial – Electric/Non-electric, Prototype/FOAK, Demonstration, Experimental
Main Intended Application (once commercial)	Off-Grid/Remote	Baseload, Dispatchable, Off-grid/Remote, Mobile/Propulsion, Non-electric (specify)
Reference Location	On-coast and inland with below-ground	On Coast, Inland, Below-Ground, Floating-Fixed, Marine-Mobile, Submerged-Fixed (Other-specify)
Reference Site Design (reactor units per site)	Single Unit	Single Unit, Dual Unit, Multiple Unit (# units)
Reactor Core Size (1 core)	Small	Small (<1000 MWth), Medium (1000-3000 MWth), Large (>3000 MWth)
Reactor Type	SFR	PWR, BWR, HWR, SCWR, GCR, GFR, SFR, LFR, MSR, ADS
Core Coolant	Na	H <sub>2</sub> O, D <sub>2</sub> O, He, CO <sub>2</sub> , Na, Pb, PbBi, Molten Salts, (Other-specify)
Neutron Moderator	None	H <sub>2</sub> O, D <sub>2</sub> O, Graphite, None, (Other-specify)
NSSS Layout	Pool-type	Loop-type (# loops), Direct-cycle, Semi-integral, Integral, Pool-type
Primary Circulation	Forced with 2 sequential pumps	Forced (# pumps), Natural
Thermodynamic Cycle	Rankine	Rankine, Brayton, Combined-Cycle (direct/indirect)
Secondary Side Fluid	Na	H <sub>2</sub> O, He, CO <sub>2</sub> , Na, Pb, PbBi, Molten Salts, (Other-specify)
Fuel Form	Fuel Assembly/Bundle	Fuel Assembly/Bundle, Coated Sphere, Plate, Prismatic, Contained Liquid, Liquid Fuel/Coolant
Fuel Lattice Shape	Hexagonal	Square, Hexagonal, Triangular, Cylindrical, Spherical, Other, n/a
Rods/Pins per Fuel Assembly/Bundle	169/Assembly	#, n/a
Fuel Material Type	Metal	Oxide, Nitride, Carbide, Metal, Molten Salt, (Other-specify)
Design Status	Detailed	Conceptual, Detailed, Final (with secure suppliers)
Licensing Status	GDR	DCR, GDR, PSAR, FSAR, Design Licensed (in Country), Under Construction (# units), In Operation (# units)

**Table 2: ARIS Parameter Fields (see also Spreadsheet “Data”) for Booklet**

ARIS Parameter	Value	Units or Examples
<i>Plant Infrastructure</i>		
Design Life	60	years
Lifetime Capacity Factor	More than 95	%, defined as Lifetime MWe-yrs delivered / (MWe capacity * Design Life), incl. outages
Major Planned Outages	- One month every two years for usual plant maintenance - One year every 30 years for refueling	# days every # months (specify purpose, including refuelling)
Operation / Maintenance Human Resources	4 staffs/shift for normal operation	# Staff in Operation / Maintenance Crew during Normal Operation
Reference Site Design	1	n Units/Modules
Gross Electrical Output	10	MWe
Non-electric Capacity	-	e.g. MWth heat at x °C, m <sup>3</sup> /day desalinated water, kg/day hydrogen, etc.
In-House Plant Consumption	-	MWe
Plant Footprint	700 (29m x 24m)	m <sup>2</sup> (rectangular building envelope)
Site Footprint	8500 (85m X 100m)	m <sup>2</sup> (fenced area)
Emergency Planning Zone	Within fenced area	km (radius)
Releases during Normal Operation	-	TBq/yr (Noble Gases / Tritium Gas / Liquids)
Load Following Range and Speed	0 - 100	x – 100%, % per minute
Seismic Design (SSE)	0.3g (Use seismic isolator)	g (Safe-Shutdown Earthquake)
NSSS Operating Pressure (primary/secondary)	0.2/0.55	MPa(abs), i.e. MPa(g)+0.1, at core/secondary outlets
Primary Coolant Inventory (incl. pressurizer)	122000	kg
Nominal Coolant Flow Rate (primary/secondary)	152/134	kg/s
Core Inlet / Outlet Coolant Temperature	355/510	°C / °C
Available Temperature as Process Heat Source	485	°C
NSSS Largest Component	RV	e.g. RPV (empty), SG, Core Module (empty/fuelled), etc.
- dimensions	25.5 / 3.4 / 86000	m (length) / m (diameter) / kg (transport weight)

ARIS Parameter	Value	Units or Examples
Reactor Vessel Material	SS304	e.g. SS304, SS316, SA508, 800H, Hastelloy N
Steam Generator Design	Helical coil type double-wall tube	e.g. Vertical/Horizontal, U-Tube/Straight/Helical, cross/counter flow
Secondary Coolant Inventory	35000	kg
Pressurizer Design	N/A	e.g. separate vessel, integral, steam or gas pressurized, etc.
Pressurizer Volume	N/A	m <sup>3</sup> / m <sup>3</sup> (total / liquid)
Containment Type and Total Volume	Dry / Inert	Dry (single/double), Dry/Wet Well, Inerted, etc. / m <sup>3</sup>
Spent Fuel Pool Capacity and Total Volume	No pool / spent fuel stored in dry cask after 30 years operation	years of full-power operation / m <sup>3</sup>
<i>Fuel/Core</i>		
Single Core Thermal Power	30	MWth
Refuelling Cycle	30	years
Fuel Material	U-10Zr	e.g. UO <sub>2</sub> , MOX, UF <sub>4</sub> , UCO
Enrichment (avg./max.)	17/19	%
Average Neutron Energy	Fast	eV
Fuel Cladding Material	HT-9	e.g. Zr-4, SS, TRISO, E-110, none
Number of Fuel "Units"	18	Assembly
Weight of one Fuel Unit	2500	Kg/assembly
Total Fissile Loading (initial)	6700(U-235)kg	kg fissile material (specify isotopic and chemical composition)
% of fuel outside core during normal operation	N/A	applicable to online refuelling and molten salt reactors
Fraction of fresh-fuel fissile material used up at discharge	20	%
Core Discharge Burnup	34	MWd/kgHM (heavy metal, eg U, Pu, Th)
Pin Burnup (max.)	55	MWd/kgHM
Breeding Ratio	0.45	Fraction of fissile material bred in-situ over one fuel cycle or at equilibrium core
Reprocessing	Depends on user country's needs (Batch treatment if it is done)	e.g. None, Batch, Continuous (FP polishing/actinide removal), etc.
Main Reactivity Control	Reflector	e.g. Rods, Boron Solution, Fuel Load, Temperature, Flow Rate, Reflectors

ARIS Parameter	Value	Units or Examples
Solid Burnable Absorber	N/A	e.g. Gd <sub>2</sub> O <sub>3</sub> ,
Core Volume (active)	1.75	m <sup>3</sup> (used to calculate power density)
Fast Neutron Flux at Core Pressure Boundary	Less than 3E16	N/m <sup>2</sup> -s
Max. Fast Neutron Flux	2.2E18	N/m <sup>2</sup> -s
<b>Safety Systems</b>		
Number of Safety Trains	Active:100% / Passive: 100%	% capacity of each train to fulfil safety function
- reactor shutdown	100,100/100,100 (metal fuel inherent passive shutdown feature)	100,100/100
- core injection	N/A	/
- decay heat removal	100/(Forced-flow IRACS or SGHARS)/100,100 (natural circulation at RVACS and IRACS)	100/100,100
- containment isolation and cooling	100/100	/
- emergency AC supply (e.g. diesels)	100/100	100/
DC Power Capacity (e.g. batteries)	-	hours
Events in which <b>Immediate Operator Action</b> is required	None	e.g. any internal/external initiating events, none
Limiting (shortest) <b>Subsequent Operator Action</b> Time	None	hours (that are assumed when following EOPs)
Severe Accident Core Provisions	No core melt	e.g. no core melt, IVMR, Core Catcher, Core Dump Tank, MCCI
Core Damage Frequency (CDF)	1E-7	x / reactor-year (based on reference site and location)
Severe Accident Containment Provisions	Top dome and reactor guard vessel with isolation valve	e.g. H <sub>2</sub> ignitors, PARs, filtered venting, etc.
Large Release Frequency (LRF)	-	x / reactor-year (based on reference site and location)
<b>Overall Build Project Costs Estimate or Range (excluding Licensing, based on the Reference Design Site and Location)</b>		
Construction Time (n <sup>th</sup> of a kind)	36	months from first concrete to criticality
Design, Project Mgmt. and Procurement Effort	-	person-years (PY) [DP&P]
Construction and Commissioning Effort	-	PY [C&C]



ARIS Parameter	Value	Units or Examples
Material and Equipment Overnight Capital Cost	-	Million US\$(2015) [M&E], if built in USA
Cost Breakdown	% [C&C] / % [M&E]	
- Site Development before first concrete	-/-	(e.g. 25 / 10 )
- Nuclear Island (NSSS)	-/-	( 30 / 40 )
- Conventional Island (Turbine and Cooling)	-/-	( 20 / 25 )
- Balance of Plant (BOP)	-/-	( 20 / 10 ) ( 5 / 15 ) ( ----- )
- Commissioning and First Fuel Loading	-/-	(to add up to 100 / 100)
Factory / On-Site split in [C&C] effort	-/-	% / % of total [C&C] effort in PY (e.g. 60 / 40 )

Wherever available, provide details on the listed subsection topics and provide clarification on the data values and/or ranges provided in Tables 1 and 2 and discuss factors that could influence them, such as local conditions.

Each Chapter should have illustrative Figures and its own list of References, as required, and one additional subsection may be added to cover items of importance specific to the design.

# ***1. Plant Layout, Site Environment and Grid Integration***

## **SUMMARY FOR BOOKLET**

The 10MWe-4S power plant can be constructed on very small site. The overall area covered by the below-grade and above grade structure of reactor plant is about 50m long by 30m wide.

The reactor building supported by seismic isolation allows the 4S to be located at any seismic condition. The shop fabrication and transportability of the reactor building including the steam generator and the secondary loop system enable shorter construction time and cost reduction. The heat from steam condenser at turbine/generator system is removed to atmosphere via air cooling tower which does not need cooling water. Considering the low probability of core melting during severe accident due to its inherent safety feature, emergency planning and evacuation is practically not necessary for 4S plant. The 4S can be also applied to multi-unit site concept.

### **1.1. Site Requirements during Construction**

The plant layout of the 4S is optimized to meet various functional requirements; safety, radiation zoning, piping, cabling, construction, access, security and so on. The general philosophy of the 4S plant layout is as follows.

- Efficient space utilization and minimization of volume of the buildings
- Horizontal seismic isolation for the reactor building
- An embedded reactor building, securing that the reactor is earth-sheltered
- Lightweight buildings to assure a high degree of transportability in construction
- The secondary sodium loop area is categorized as a non-radiation-controlled area. To achieve this, a sufficient shielding for the IHX is provided.

Figure 3 shows the 4S plant layout (10MWe) and Figure 4 shows the vertical cross section of the 4S reactor building and turbine building.

The 4S adopts the cylindrical/spherical containment system. Figure 5 shows containment boundary of the 4S. The containment system consists of the GV and the top dome, which covers the upper region of the RV, a shielding plug and the equipment located on the shielding plug. The GV provides the second boundary for the primary sodium at the outer side of the RV. For the mitigation of sodium fire, nitrogen gas is provided inside the top dome.

In reactor building, the secondary sodium loop area is categorized as a non-radiation-controlled area.

The basement of reactor building is built in the below-grade by concrete so the soil condition can be acceptable for wide range of site conditions.

The shop fabrication and transportability of reactor building including the steam generator (SG) and secondary loop system enable shorter construction and cost reduction. Figure 6 shows the steel concrete composite of reactor building is transported by barge and settled on the basement of reactor building. The large component such as reactor vessel is also transported by barge. Shop fabrication and barge transportation can reduce the construction time. For the case of inland site, steel composite is divided to small part which can be transported by railroad and/or truck. The RV and the SG are also transported by railroad and/or truck from a port to site. Spent fuel will be cooled in reactor for one year after 30 years' operation, and then stored in dry cask. There is no need for spent fuel pool.

## 1.2. Site Considerations during Operation

The heat generated in the core is transferred to secondary sodium via the IHX located at the upper region in the RV. Then, the heat is transferred to water/steam system via the SG to produce electricity by turbine/generator. The residual heat is transferred to the condenser, and finally it is released to atmosphere via air-cooling tower. The cooling tower is a dry type and does not need water. Figure 7 shows the turbine heat cycle flow diagram. While steam turbine system is used, the amount of required water is not large due to closed cycle steam turbine system.

The site staffs during operation are 4 operators and 5 guards for one shift.

As for maintenance, reactivity control system and turbine system are checked periodically and no special tools are needed.

The emergency planning zone (EPZ) of the 4S was evaluated by applying NUREG-396 Class 9 event. Considering the low probability of core melting for severe accident of the 4S due to its inherent safety feature, the all fuel cladding failure in the core without fuel melting is hypothetically assumed to evaluate dose rate during severe accident. The result of TEDE (total effective dose equivalent) is 5mSv at 200m from reactor within the site protective fence during one month upon the event. This is less than 10 mSv which is the protective action initiating dose (the US EPA) and it means that emergency planning and evacuation is practically not necessary for 4S plant.

Decommissioning at the end-of-life was evaluated such as sodium deposition and reactor vessel deposition can be done by following decommissioning method of EBR-II and LWR plant in the US. Sodium will be disposed by following experiment of EBR-II. The RV without fuel and sodium will be filled with concrete and transported to disposal site.

## Reference

- 1) K. Arie, "Application of Small Fast reactor 4S for Energy Supply security" IAEA Technical meeting on Options to Enhance Energy Supply Security with NPPs Based on SMRs Vienna, October 3th -6th, 2011.  
[https://www.iaea.org/nuclearenergy/nuclearpower/Downloadable/Meetings/2011/2011-10-03-10-06-TM-NPTD/1-Monday/6 JAPAN TOSHIBA Arie TM3-6Oct2011.pdf](https://www.iaea.org/nuclearenergy/nuclearpower/Downloadable/Meetings/2011/2011-10-03-10-06-TM-NPTD/1-Monday/6%20JAPAN%20TOSHIBA%20Arie%20TM3-6Oct2011.pdf)
- 2) Y. Tsuboi et al., "Design of the 4S reactor" Nuclear Technology, Vol.178, PP201-217, May, 2012
- 3) ML081440765, "4S Design Description" on May, 2008.  
<http://adamswebsearch2.nrc.gov/IDMWS/ViewDocByAccession.asp?AccessionNumber=ML081440765>
- 4) ML11277A234, Submittal of Technical Report "Evaluation for 4S Emergency Planning Zone", September, 2011.  
<http://adamswebsearch2.nrc.gov/IDMWS/ViewDocByAccession.asp?AccessionNumber=ML11277A234>

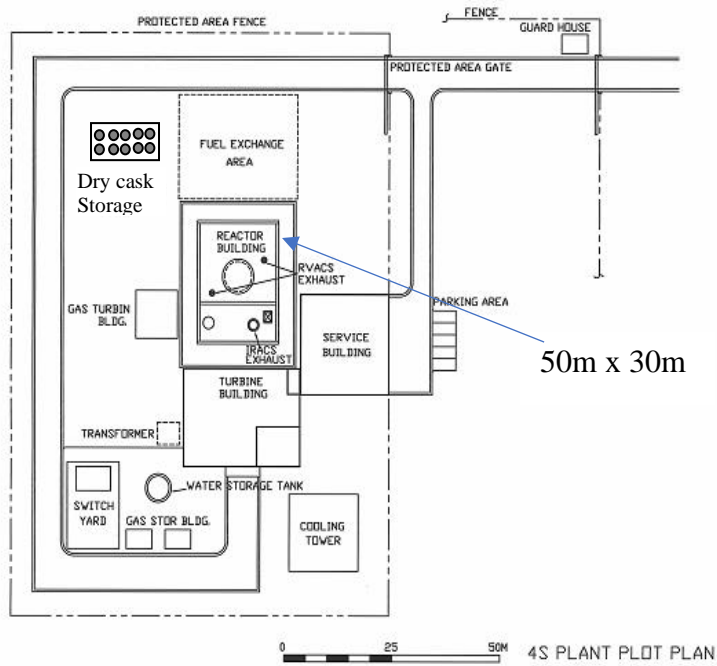

Figure 3 4S Plant Layout Diagram <sup>1)</sup>

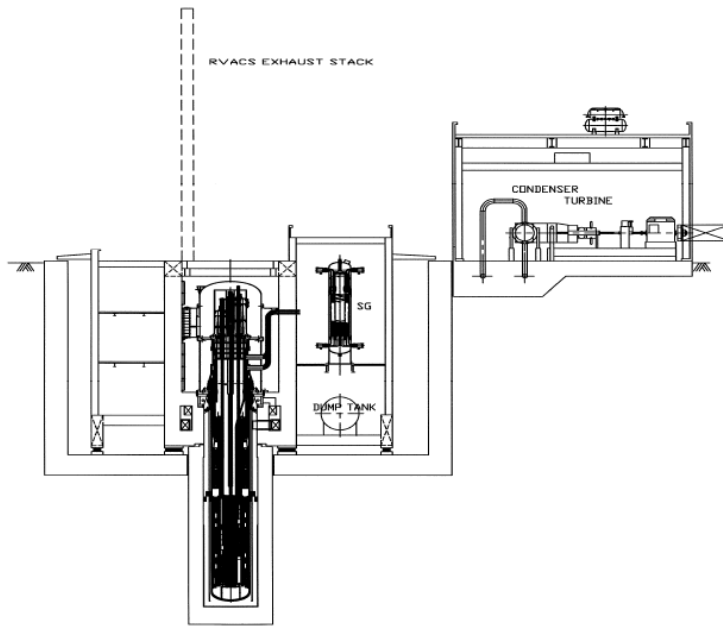

Figure 4 Vertical Cross Section of 4S Plant (10MWe)<sup>2)</sup>

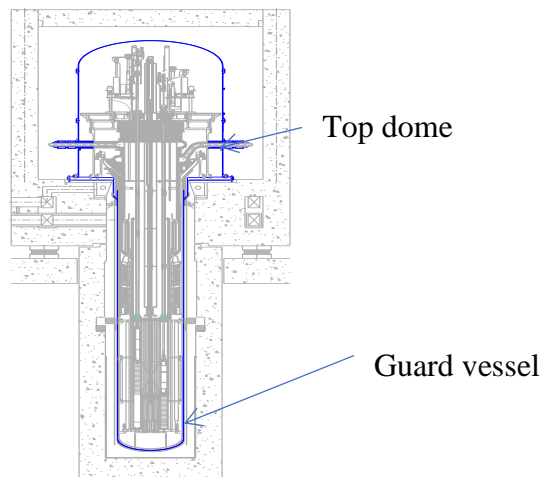

Figure 5 Containment Boundary<sup>2)</sup>

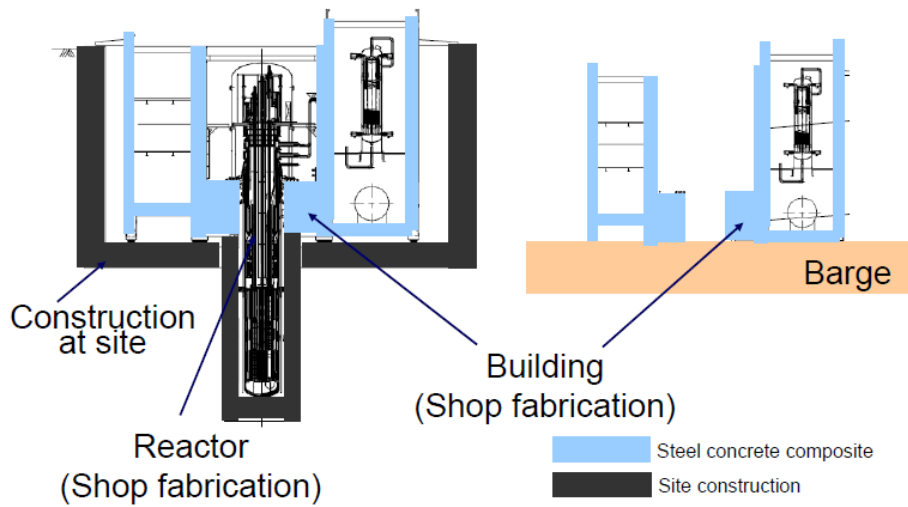

Figure 6 Reactor Building Construction Method<sup>1)</sup>

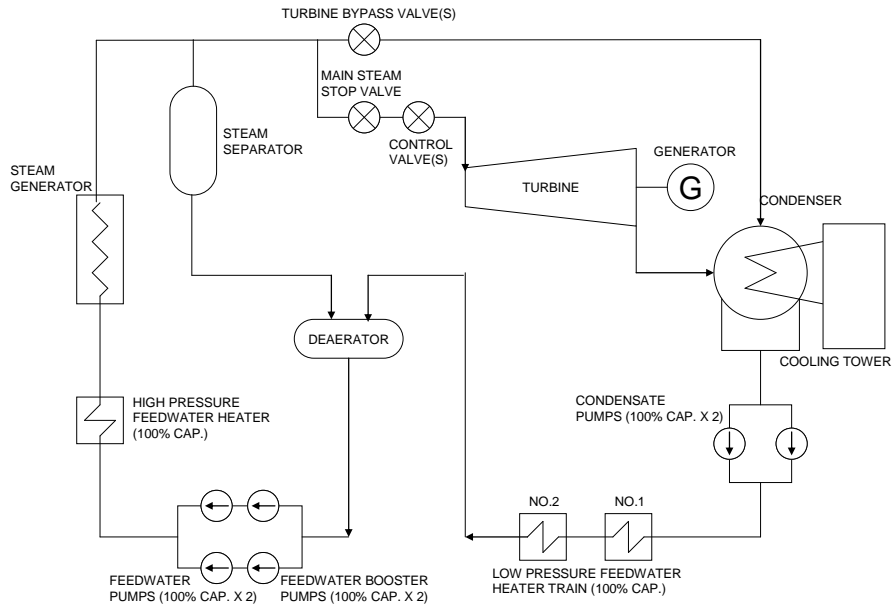

Figure 7 Turbine Heat Cycle Flow Diagram<sup>2)</sup>

### 1.3. Grid Integration

There are two offsite power grid line connected to the 4S plant. The power line is connected to the main power transformer and generator circuit breakers (GCB), which can isolate the fault current of the plant main generator (PMG). The grid side of the GCB terminal is also connected to the unit auxiliary transformer (UAT). The power line and PMG can supply power to an onsite power system via the UAT. As the PMG and the associated steam turbine system have 100% steam bypass capability and onsite combustion turbine generators for emergency power, the PMG can maintain generation or restart without electric power from the offsite network (i.e., black startup). By 100% turbine bypass, load following capability is 0 to 100% power.

### 2.2 Onsite power supply

#### (1) AC power supply

AC power supplies consist of four Non-class 1E buses. These buses contain air circuit breakers for 100 kW or larger loads and molded case circuit breakers for loads less than 100 kW.

#### (2) Class 1E Power Supply

The two Class 1E buses are separated from each other and separated from the Non-class 1E electric systems as a part of the reactor safety system configuration. Each 1E Bus is provided with a separate Emergency Diesel Generator (EDG) for backup power.

#### (3) Non-class 1E Power Supply

The four Non-class 1E (N1E) buses (A) and (B), (C) and (D) are settled.

Figure 8 shows the principal single-line diagram of 4S.

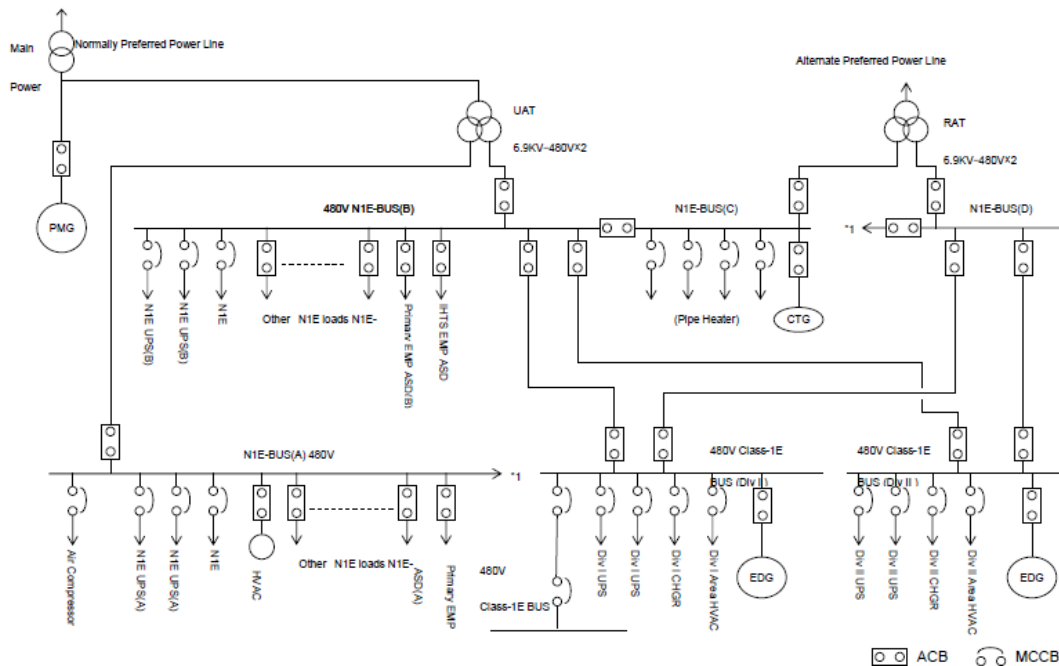

Figure 8 Principal Single-Line Diagram

### Reference

1) ML081440765: "4S Design Description" on May, 2008

<http://adamswebsearch2.nrc.gov/IDMWS/ViewDocByAccession.asp?AccessionNumber=ML081440765>

## ***2. Technical NSSS/Power Conversion System Design***

### **SUMMARY FOR BOOKLET**

- **Primary and Secondary Circuits**

The primary sodium circulates from the primary electro-magnetic (EM) pumps downward, driven by its pump pressure, and flows through radial shielding assemblies located in the region between the RV and the cylindrical dividing wall. The coolant flow changes its direction at the bottom of the RV and then goes upward, mainly into the fuel subassemblies and partly into the movable reflectors. The heated primary sodium then goes into the IHX to transfer heat to the secondary sodium.

The secondary sodium loop is an intermediate heat transport system and consists of the secondary EM pump, piping, intermediate reactor auxiliary cooling system (IRACS), dump tank, and SG. The secondary sodium coolant heated in the IHX flows inside the piping to the SG where heat is transferred to water/steam to be supplied to the steam turbine generator. For decay heat removal, two independent passive systems are provided.

- **Reactor Core and Fuel**

The core and fuel are designed to eliminate the need for refuelling during 30 years for the 10 MWe-4S and to make reactivity temperature coefficients negative.

U-Zr metal fuel alloy is applied. The core can be operated for 30 years by axially moving reflectors installed at the outside of the core, upward from the bottom of the core. No reloading or shuffling of fuel is required during the whole fuel lifetime.

- **Fuel Handling**

The fuel handling system consists of the fuel handling and transfer system, refuelling enclosure, and fuel receiving/shipping facility. It is used at initial fuel loading and discharging after the end of the 30 years' core life. The system is not usually located at the reactor site during the reactor operation, and is transported there when needed.

- **Reactor Protection**

Reactivity and power are controlled by the six-segment cylindrical reflector surrounding the core and the fixed absorber during normal operation. To shut down the reactor, the reflector is released and falls down by gravity, causing reactor shutdown. The shutdown rod at the core center is also inserted upon a scram to provide an independent and redundant mean for the reactor shutdown.

- **Secondary Side**

The 4S plant has one turbine generator set. The main turbine is a 3600 rpm, single flow, non-reheat machine. The turbine consists of one integral single flow cylinder casing and a conventional steam sealing system.

- **Containment/Confinement**

The containment system consists of a guard vessel, top dome, airlock, cable penetrations, and piping penetrations. The steel GV closely surrounds the RV.

- **Electrical, I&C and Human Interface**

The instrument and control system consists of safety related and non-safety related system. The system related to safety includes the reactor protection system (RPS), the engineering safety feature actuation system (ESFAS) and the remote shutdown system (RSS). These systems have the safety Class 1E instruments.

The RPS is plant protection system to initiate reactor trip during abnormal plant condition.



### 2.1. Primary and Secondary Circuits

Figure 9 shows the schematic diagram of the heat transfer systems. The primary sodium circulates from the primary electro-magnetic (EM) pumps downward, driven by its pump pressure, and flows through radial shielding assemblies located in the region between the RV and the cylindrical dividing wall. The coolant flow changes its direction at the bottom of the RV and then goes upward, mainly into the fuel subassemblies and partly into the movable reflectors. The heated primary sodium then goes into the IHX to transfer heat to the secondary sodium.

The secondary sodium loop is an intermediate heat transport system and consists of the secondary EM pump, piping, the intermediate reactor auxiliary cooling system (IRACS), dump tank, and SG. The secondary sodium coolant heated in the IHX flows inside the piping to the SG where heat is transferred to water/steam to be supplied to the steam turbine generator.

For decay heat removal, two independent passive systems are provided. Figure 10 shows the schematic diagram of the reactor vessel auxiliary cooling system (RVACS) and the IRACS. The RVACS is completely passive and removes decay heat from the surfaces of the GV by natural circulation of air. There is no valve, vane, or damper in the flow path of the air. The IRACS removes decay heat by air cooler which is arranged in series with the secondary sodium loop. Heat is removed by forced sodium and air circulation at the IRACS when electric power is available. In addition, the IRACS can also remove the required amount of heat solely through natural circulation of both air and sodium during loss of power events.

### 2.2. Reactor Core and Fuel

The core and fuel are designed to eliminate the need for refuelling during 30 years for the 10 MWe-4S and to make reactivity temperature coefficients negative. Metal fuel, which has an excellent thermal conductivity, is applied. The core can be operated for 30 years by axially moving reflectors installed at the outside of the core, upward from the bottom of the core. No reloading or shuffling of fuel is required during the whole fuel lifetime. Figure 11 shows the fuel assembly. The fuel element (fuel pin) consists of fuel slugs of U-Zr alloy, bonding sodium, cladding tube, and plugs at both ends. A fission gas plenum of an adequate length is located at the upper region of the fuel slugs.

### 2.3. Fuel Handling

Figure 12 shows the fuel handling system<sup>2)</sup>. It consists of the fuel handling and transfer system, refuelling enclosure, and fuel receiving/shipping facility. The fuel handling system accepts new fuel subassemblies and loads them in the core at initial fuel loading. The spent fuel assemblies, which is cooled in reactor for one year, are unloaded from the reactor and stored in the fuel cask by fuel handling system. The fuel handling system is used after the end of the 30 years' core life. It is not usually located at the reactor site during the reactor operation, and is transported there when needed.

### 2.4. Reactor Protection

The 4S core is controlled by reflector. Figure 13 shows the core cross sectional view and the reflector configuration. The core consists of 18 hexagonal fuel assemblies and 1 central control assembly containing a shutdown rod and fixed absorber. Reactivity and power are controlled by six-segment cylindrical reflector surrounding the core. The reflector and the fixed absorber maintain the criticality until the end of Life.

To shut down the reactor, reflector is released and falls down by gravity, causing reactor shutdown. The shutdown rod at the core center position is also inserted upon a scram to provide an independent and redundant mean for the reactor shutdown.

Figure 14 shows that the reactor protection system initiates protective action when any of the safety function parameters, including neutron flux, primary outlet temperature of the IHX, the primary EM pump voltage/current, the reactor vessel sodium level, the voltage of power line and seismic acceleration, exceeds the threshold values.

## 2.5. Secondary Side

Figure 7 shows the turbine heat cycle diagram. The 4S plant has one turbine generator set. The main turbine is a 3600 rpm, single flow, non-reheat machine. The turbine consists of one integral single flow cylinder casing and a conventional steam sealing system. Steam at 107 atg and 453°C is generated by the steam generator and led to the turbine throttle section. The steam is exhausted from the main turbine directly to the condenser. A single generator is on a common shaft with the turbine rotor. The turbine generator produces 10 MWe (gross) of electricity, exhausting to the condenser at 700 mm of mercury vacuum pressure. The condenser is cooled by air.

## 2.6. Containment/Confinement

The containment system consists of a guard vessel, top dome, airlock, cable penetrations, and piping penetrations. The steel GV closely surrounds the RV. If the RV should leak at any point below the sodium pool surface level, the guard vessel will retain the sodium. Even if the maximum volume of the sodium leak into the void between the RV and the GV, the core remains covered by sodium, and the sodium flow circuit is maintained.

Figure 5 shows the containment system. The GV provides the second boundary for the primary sodium at the outer side of the RV. To prevent sodium fire, nitrogen gas is provided inside the top dome. The RVACS removes decay heat in reactor via the GV.

## 2.7. Electrical, I&C and Human Interface

The system related to safety includes the reactor protection system (RPS), the engineering safety feature actuation system (ESFAS) and the remote shutdown system (RSS). These systems have the safety Class 1E instruments.

The RPS is plant protection system to initiate reactor trip at abnormal plant operation condition. The trip parameters are as follows.

- Reactor core neutron flux
- Liquid sodium level in the RV
- Supply voltage/current for the main/intermediate loop EM pumps
- Primary outlet temperature of the IHX
- Voltage of power line
- Seismic acceleration

The ESFAS controls the decay heat removal system and the containment isolation system. As for decay heat removal system, the dumper of air cooler of the IRACS is opened at trip. When the leakage of radioactive material inside the containment occurs, some valves of pipes are closed to prevent release of the radioactive materials.

The RSS provides means to shutdown the reactor from the main control room which is located outside.

The system related to non-safety consists of the plant control system (PCS) and the interface reactor system (IRS). The PCS includes instrument of process sensors and provides the proper coordination of reactor power, primary sodium coolant flow, secondary coolant flow, steam generator feed water, and main-steam flow of turbine generator system from plant start up to

rated power operation. The IRS includes plant supporting system such as radiation monitoring, fire protection and impurity monitoring of coolant. Control room is settled in the reactor building which is supported by horizontal seismic isolator and embedded underground.

Reference

- 1) Y. Tsuboi et al., "Design of the 4S reactor", Nuclear Technology, Vol.178, PP201-217, May 2012.
- 2) ML081440765, "4S Design Description", May, 2008.  
<http://adamswebsearch2.nrc.gov/IDMWS/ViewDocByAccession.asp?AccessionNumber=ML081440765>

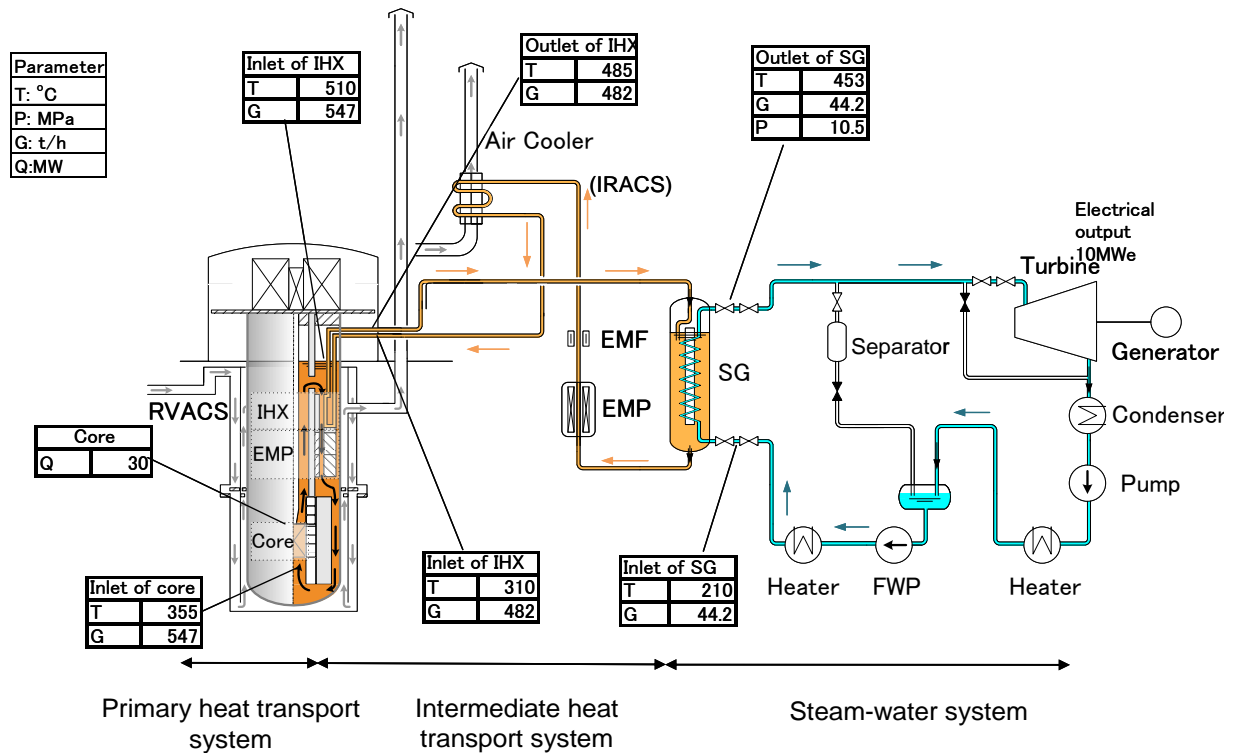

Figure 9 Simplified Schematic Diagram of 4S Plant of 10MWe<sup>1)</sup>

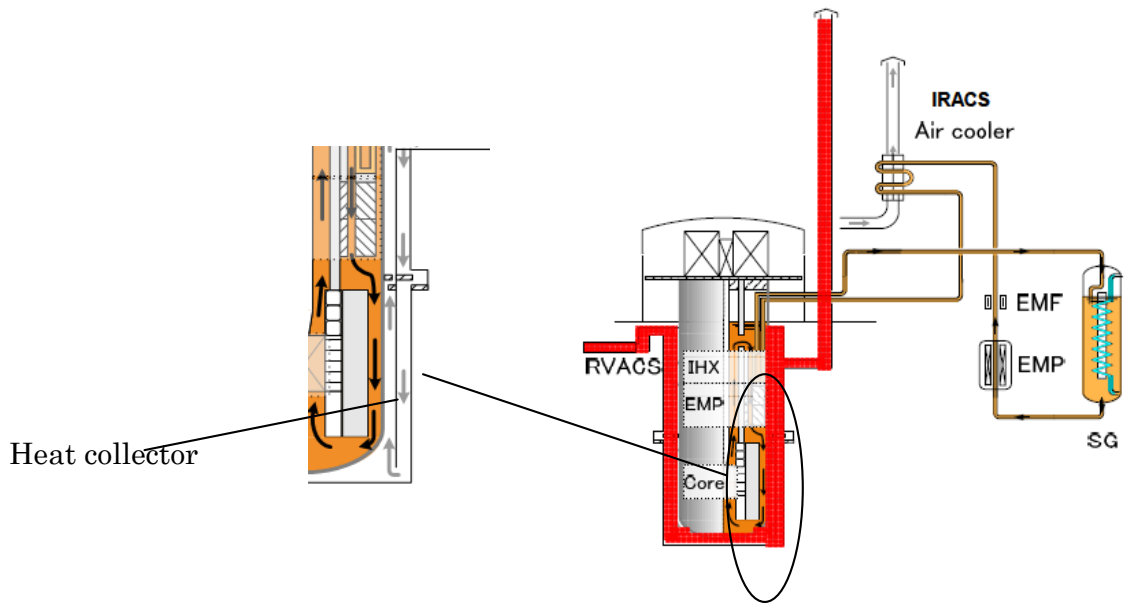

Figure 10 Residual Heat Removal System<sup>1)</sup>

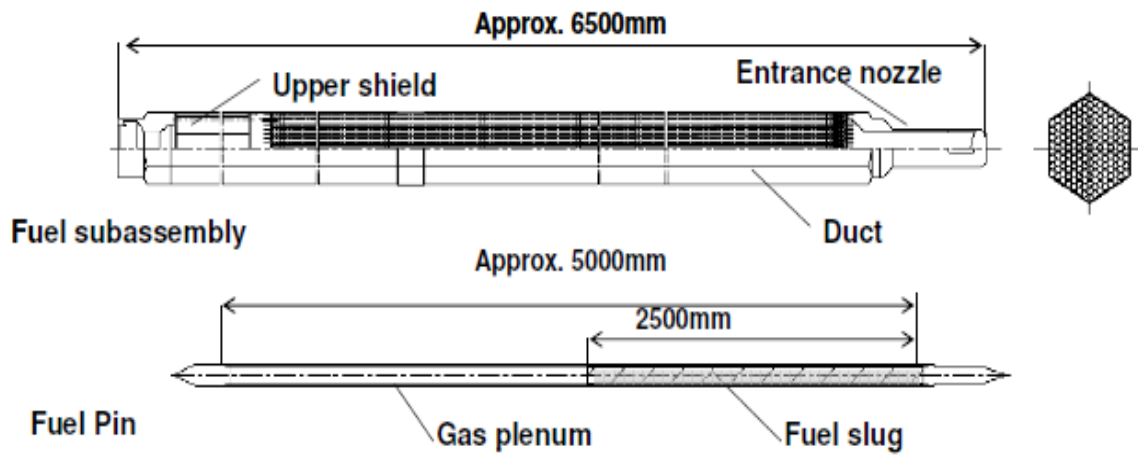

Figure 11 Fuel Assembly<sup>1)</sup>

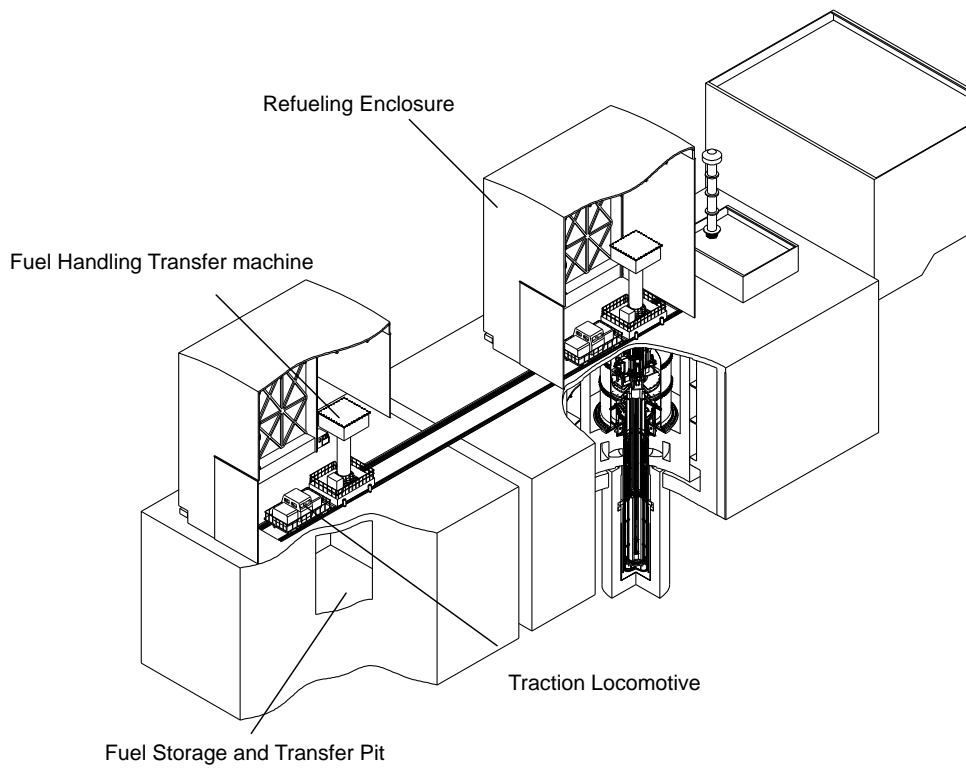

Figure 12 Fuel Handling System<sup>2)</sup>

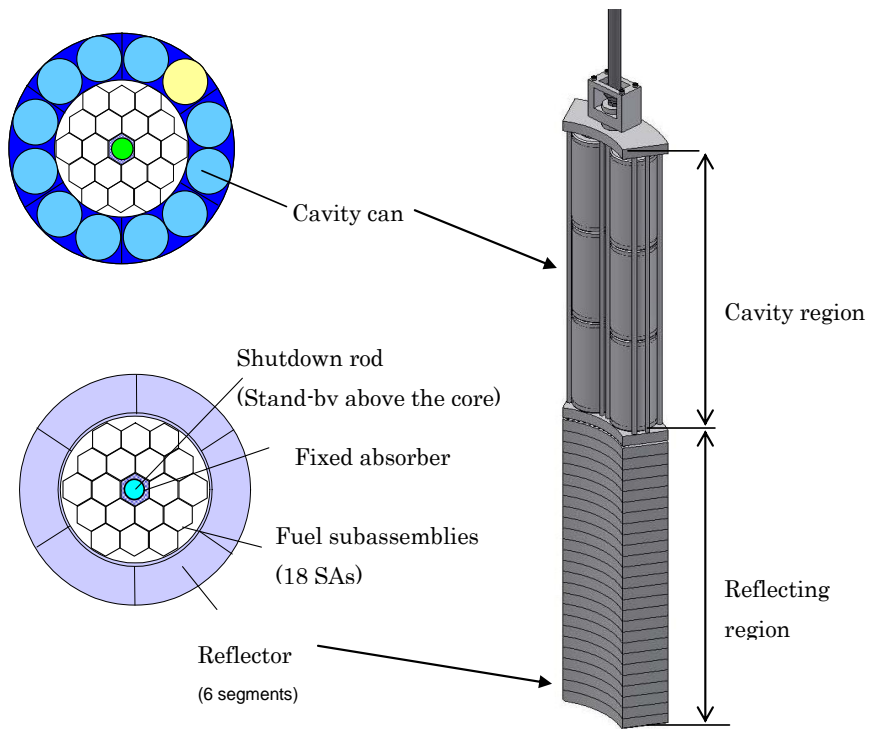

Figure 13 Core Cross Sectional View and Reflector Configuration

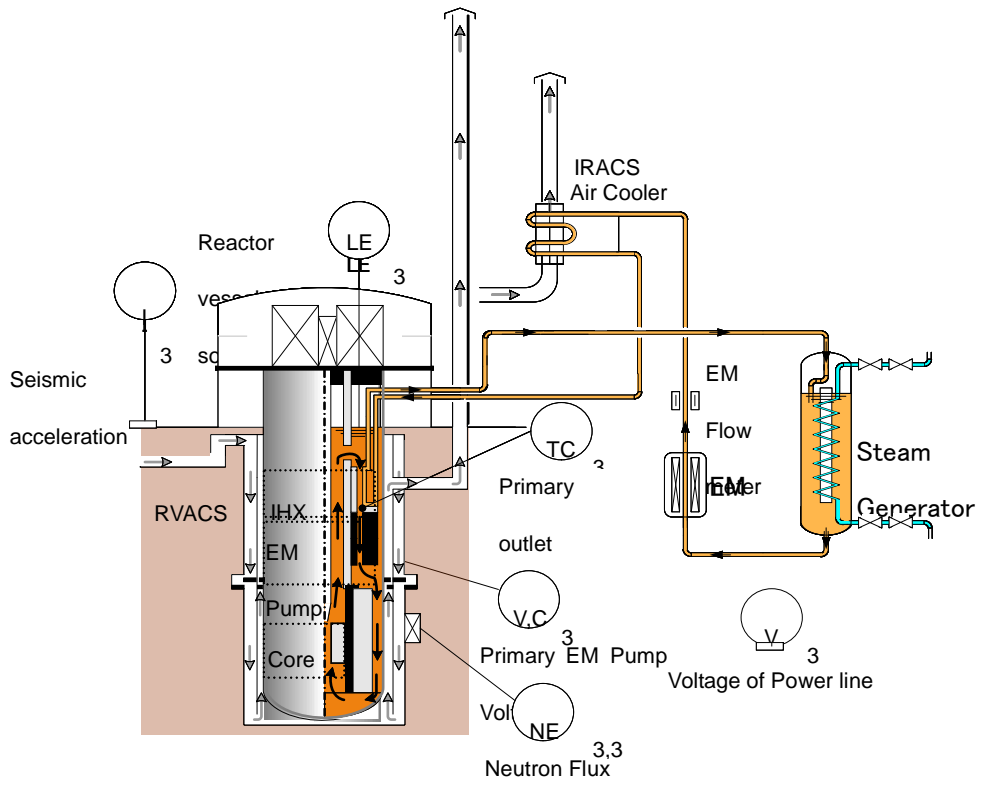

Figure 14 Reactor Protection System<sup>2)</sup>

### ***3. Technology Maturity/Readiness***

#### **SUMMARY FOR BOOKLET**

Application of the 4S reactor is planned such as:

- Electricity/heat supply for remote area community,
- Electricity supply for mining site
- Hot steam supply for oil sand /oil shale recovery
- Electricity supply for seawater desalination
- Electricity/heat supply for hydrogen production

In addition, the hybrid system by combination of the 4S & Smart Grid & Energy Storage System is also planned

Licensing activities for the 4S design is initiated with the U.S.NRC in 2007. In pre-application review, four-times meetings had been held in the past and 18 technical reports have been submitted to the U.S.NRC.

The key technologies such as the EM pump, the double-wall steam generator etc. have been mostly developed. The detailed design and safety analysis for design approval has being conducted.

#### **3.2 Reactors under Licensing Review**

Licensing activities for the 4S design initiated with the U.S.NRC in 2007. In pre-application review, four-times meetings had been held in the past and 18 technical reports have been submitted to the U.S.NRC.

Development for the 4S related technology had been performed in the past; the full scale test of EM pump and electromagnetic flow meter in Toshiba sodium loop facility, development of manufacturing technology of double-wall steam generator, and critical experiment in FCA were done, sponsored by the Japanese government. Thus, the key technologies have been mostly developed. Toshiba is conducting the detailed design and safety analysis for design approval.

Application of the 4S reactor is planned such as:

- Electricity/heat supply for remote area community,
- Electricity supply for mining site
- Hot steam supply for oil sand /oil shale recovery
- Electricity supply for seawater desalination
- Electricity/heat supply for hydrogen production

In addition, the hybrid system by combination of the 4S & Smart Grid & Energy Storage System is also planned as shown in Figure 15.<sup>1)</sup> This is an integrated system to supply electricity, heat, hydrogen and water to society. The combination of the smart grid and the energy storage system with the 4S brings more flexibility and broader application. The hydrogen energy storage technology based on the high temperature electrolysis (HTE) process has being developed<sup>1)</sup>. The system converts electricity to hydrogen by Solid Oxide Electrolysis Cell (SOEC) to store energy as hydrogen, and re-converts it to electricity by Solid Oxide Fuel Cell (SOFC) to supply electricity as demand. The electrochemical voltage efficiency of the cell for the conversion has been confirmed more than 90% through our test Since the energy storage system provides a solution against the intermittency issue of renewable energy such as wind and solar, this hybrid system fits well to the growing trend of renewables and contributes to reducing carbon footprint for the world.

Moreover, considering the highly safe characteristics of the 4S such as small emergency planning zone, the 4S-based Hybrid System can be applied for urban cities and a backup energy system at important "critical" areas.

Toshiba Energy Systems & Solutions Corporation (Toshiba ESS) is continuing to seek customers.

#### Reference

1) K. Arie, "Application of Small Fast reactor 4S for Energy Supply security", IAEA Technical meeting on Options to Enhance Energy Supply Security with NPPs Based on SMRs Vienna, October 3th - 6th, 2011.

[https://www.iaea.org/nuclearenergy/nuclearpower/Downloadable/Meetings/2011/2011-10-03-10-06-TM-NPTD/1-Monday/6\\_JAPAN\\_TOSHIBA\\_Arie\\_TM3-6Oct2011.pdf](https://www.iaea.org/nuclearenergy/nuclearpower/Downloadable/Meetings/2011/2011-10-03-10-06-TM-NPTD/1-Monday/6_JAPAN_TOSHIBA_Arie_TM3-6Oct2011.pdf)

2) T. Kameda et. al., "Development of the Hydrogen Power Storage System for Electric-Load Leveling of Renewable Energy", Hydrogen Energy System, Vol. 36, No. 3 (2011) [in Japanese].

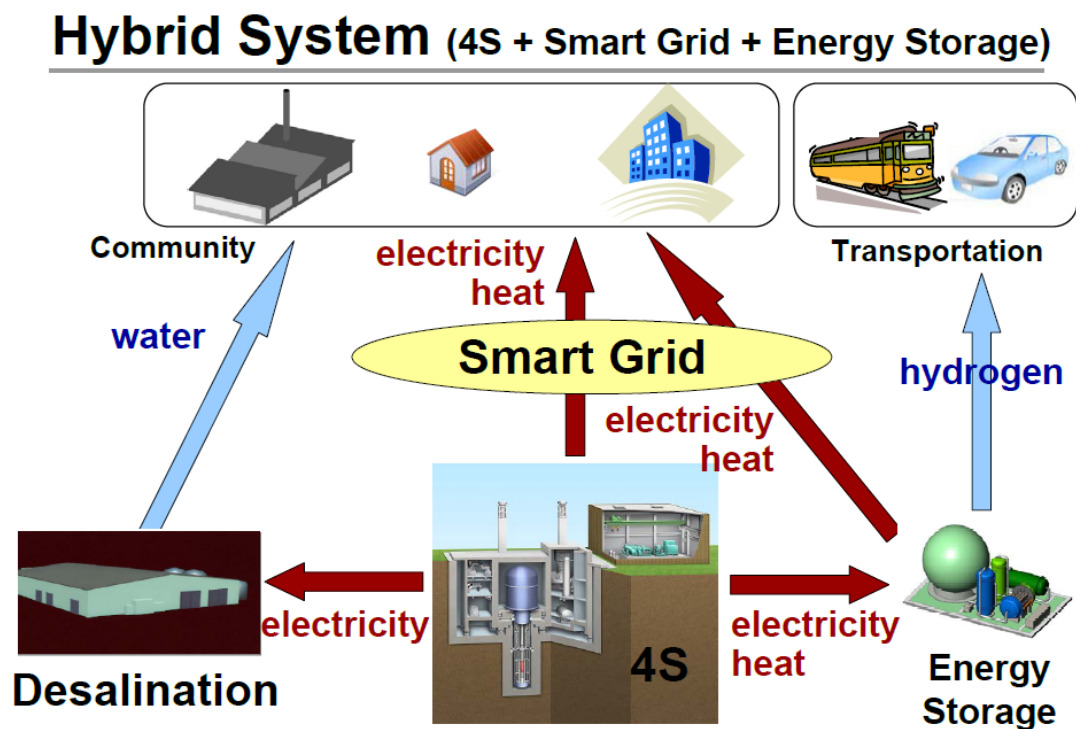

Figure 15 The Concept of the 4S-based Hybrid System in Combination with Smart Grid and Energy Storage<sup>1)</sup>



## 4. Safety Concept (3 – 4 pages)

### SUMMARY FOR BOOKLET

The philosophy of the 4S safety concepts is to put an emphasis on simplicity achieved using passive and inherent safe features as a major part of the defence in depth (DiD) strategy. The ultimate target of the 4S safety concept is to eliminate the requirement of evacuation as an emergency response measure. The concept provides three functions in each phase of abnormal operation or accident: prevent, mitigation, and confinement. The safety systems of the 4S consists of: redundant shutdown system, passive decay heat removal systems without removal external power supply, emergency power system, and reinforced reactor building. The active and passive/inherent safe features of the 4S as follows.

(a) Engineered safety systems: In addition to inherent safety features, there are two independent systems for reactor shutdown. The primary shutdown system provides drop of the reflectors and backup system provides insertion of ultimate shutdown rod. These are fallen by gravity on scram.

(b) Decay heat removal system(DHRS): The water/steam DHRS system is available during normal shutdown. When the system is not available, two independent passive systems are provided; the reactor vessel auxiliary heat removal system(RVACS) and the intermediate reactor auxiliary heat removal system (IRACS).

(c) Containment system: The 4S adopts a cylindrical/spherical containment system. The system consists of the guard vessel (GV) and the top dome.

#### 4.1 Safety Philosophy and Implementation

The philosophy behind the 4S safety concepts is to put an emphasis on simplicity achieved by strong reliance on passive and inherent safe features as a major part of the defence in depth (DiD) strategy. The ultimate target of the 4S safety concept is to eliminate the requirement of evacuation as an emergency response measure. The concept provides three functions to be shouldered by the DiD in each phase of the abnormal operation or an accident. These three functions are the following:

- Prevention of accidents
- Mitigation of accident consequences
- Confinement of radioactive material

#### *Provisions for simplicity and robustness of the design*

Incorporation of several passive and inherent safe features, such as low power density in the core, good thermal characteristics of the sodium-bonded metal fuel, negative reactivity temperature coefficients, passive shutdown, passive decay heat removal by both natural circulations of the coolant and natural air draft, and a large coolant inventory, are the key important provisions for simplicity and robustness of the 4S design.

#### *Active and passive systems and inherent safe features*

The active and passive systems and inherent safe features of the 4S are applied for the following objectives.

- To reduce the probability of component failure, the inherent features of the 4S design are as follows.

- Elimination of active systems from the reactor side
- Elimination of moving parts (use of static devices such as the EM pumps)
- No refuelling during 30 years and no systems relevant for fuel reloading or shuffling
- To prevent core damage in accidents, the active and passive systems and inherent safe features of the 4S are as follows.
  - Two independent active shutdown systems
    - Actively-initiated drop of several sectors of the reflector
    - Active insertion of the ultimate shutdown rod
  - Enhancement of inherent safe features by use of metal fuel (lower accumulated enthalpy of fuel)
  - Negative reactivity temperature coefficients (an inherent safe feature)
  - Higher capability for natural circulation of sodium after a pump trip enabled by low pressure drop in the fuel subassemblies and a simple flow path inside the reactor (an inherent safe feature)
  - Two fully passive decay heat removal systems
    - The RVACS based on natural circulation of primary sodium and natural air draft around the guard vessel
    - The IRACS based on natural circulation of secondary sodium and natural air draft through the air heat exchanger
  - Large inventory of primary sodium (an inherent safety feature)
- To confine the radioactive materials, the design features of the 4S are as follows.
  - Multiple barriers against fission product release
    - Fuel cladding
    - Primary sodium coolant to trap radionuclides
    - Reactor vessel, upper plug and the IHX tubes
    - The top dome and the guard vessel
  - The small radioactive inventory of a small sized power reactor
- To prevent sodium leakage and to mitigate the consequences, the design features of the 4S are as follows.
  - Double boundaries for sodium in the primary system and the important parts of the secondary system with a detection system for small leakages to prevent simultaneous failure of the boundaries.
    - The RV and the GV for the primary sodium
    - The SG with the double-wall heat transfer tubes For secondary sodium
  - A passive sodium drain system from the SG to the dump tank; if a sodium-water reaction occurs, an increase in cover gas pressure in the SG would cause disk rupture and make secondary sodium to drain rapidly to the dump tank located beneath the SG.

### ***Structure of the defence in depth (DiD)***

Some major highlights of the 4S design and systems, structures and components corresponding to various levels of the DiD are brought out as follows.

#### ***Level 1: Prevention of abnormal operation and failure***

##### **(A) Prevention of loss of coolant**

- Double boundaries for the primary sodium and for the secondary sodium in the SG tubes which have continuous leak detection systems during operation;

##### **(B) Prevention of loss of flow**

- Primary EM pumps are arranged in two units connected in series where each single unit takes on one half of the pump head
- A combined system of the EM pumps and the synchronous motor systems (SM) ensures a sufficient flow coastdown characteristics

##### **(C) Prevention of transient overpower**

- Elimination of feedback control of the movable reflectors
  - A pre-programmed reflector-drive system which drives the reflector without feedback signals
- Limitation of high-speed reactivity insertion by adopting the very low speed driving system
  - The moving speed of the reflector is approximately 1mm/week
- Limitation of reactivity insertion at the start-up of reactor operation

##### **(D) Prevention of sodium-water reaction**

- A leak detection system in the double-wall heat transfer tubes of the SG using wire meshes and helium gas in the small gap between the tubes, which enables early detection of the one side tube failure
  - An inner tube failure detection (water/steam side of the boundary)
  - An outer tube failure detection (secondary sodium side of the boundary)

#### ***Level 2: Control of accidents within the design basis***

The design features of the 4S supporting Level 2 of the DiD are as follows.

- Increased reliability of the reactor shutdown systems achieved by two independent systems with each of them having enough reactivity for shutdown
  - Drop of several sectors of the reflector
  - Insertion of the ultimate shutdown rod
- Increased reliability of the decay heat removal systems achieved by two passive systems based on natural convection
- Increased reliability of the sodium-leakage prevention systems achieved by the double-wall tube SG with detection systems for both inner and outer tubes

#### ***Level 3: Control of severe plant conditions including prevention of accident progress and mitigation of the consequences***

The design features of the 4S supporting Level 3 of the DiD are as follows.

- Inherent safe features of a metal fuel core, such as excellent thermal conductivity and low accumulated enthalpy
- Negative reactivity temperature coefficients
- The fully passive decay heat removal system (RVACS) based on natural air draft and natural circulation of sodium
- Large inventory of primary sodium for increased grace periods
- The rapid system of sodium drain from the SG to the dump tank as a mitigation for sodium-water reaction

*Level 4: Mitigation of radiological consequence of significant release of radioactive materials*

The inherent and passive safety features of the 4S are capable to eliminate occurrence of fuel melting and sodium boiling in anticipated transients without scram (ATWS).

A preliminary evaluation on the source term and their behaviour has been conducted assuming all fuel element claddings (approximately 3000 fuel pins) hypothetically fails to calculate site suitability source term (SSST). The results are as follows.

- Plutonium (Pu) is retained in the metal fuel slug because fuel melting never occur.
- Cesium (Cs) could be solidified and retained in a lower temperature area along the leakage path from the coolant to the reactor vessel, including the upper plug and the IHX, and then to the containment.
- Iodine (I) is retained in the sodium coolant as NaI compound because fuel melting never occurs. Therefore, iodine migration does not occur.

It was assumed that 100 % of the noble gases including krypton and xenon are released from the sodium coolant to the cover gas. Further migration of the noble gases was considered for 30 days as follows.

- At a leak rate of 1 %/day from cover gas through the reactor vessel, upper plug and IHX and then to the top dome
- At a leak rate of 1 %/day from the top dome to the reactor building
- Noble gases in the reactor building were assumed to be released to the off-site.

The analytical results obtained show that the dose equivalent is 0.01 Sv at a distance of 50 m from the reactor. It means that only 50 m are required as a site boundary for the 4S.

### 3.1. Transient/Accident Behaviour

#### ***Design basis accidents and beyond design basis accidents***

A major objective of the 4S design is to ensure the capability of withstanding a wide range of postulated events without exceeding the specified temperatures of fuel, cladding, and coolant boundaries, thereby maintaining integrity of fuel pin and coolant boundary. For the safety analysis of the 4S, design basis events (DBEs), which include anticipated operational occurrences (AOOs) and design bases accidents (DBAs), have been identified systematically with consideration of the 4S operation cycle and the events postulated for MONJU, DFBR (Japan), and LWRs. A variety of events have been considered in the following categories.

- Power transients
- Loss of flow
- Local fault

- Sodium leakage
- Balance of plant (BOP) failure and loss of off-site power
- Multiple system failures

For the safety analysis, beyond design basis events (BDBEs) have been identified in a similar manner. The criterion for ATWS is as follows.

- ATWS events
  - Fuel maximum CDF (Cumulative Damage Fraction) less than 0.1
  - Coolant boundary limit does not exceed the service level D in American Society of Mechanical Engineers (ASME)

For the ATWS events, the 4S design is validated using upper side of 95 percent probability at a 95 percent confidence level for the acceptance criterion. The basic analysis procedure for ATWS has been derived from [1]. Code Scaling, Applicability and Uncertainty Evaluation (CSAU) have been adopted for the ATWS analysis. Representative analytical results on AOO, DBA, and ATWS are summarized below.

#### ***Loss of Offsite Power (AOO event)***

The loss of offsite power leads to simultaneous trip of the primary circulation pumps, the intermediate-loop circulation pump, and the feedwater pump. The power supply for the primary and intermediate-loop circulation pumps is switched to the coastdown power supply from the individually independent motor-generator (MG) sets. The flow rates of the primary and intermediate coolant then coast down in response to the reduction of the circulation pump head.

Reactor scram is caused by a low signal in the normal bus voltage of the reactor protection system. With the occurrence of the scram signal, the reflectors are descended, the shutdown rod is inserted, and the reactor power drops rapidly. The signal of the reactor protection system also triggers the IRACS residual heat removal start-up, whereby the air-side damper of the air cooler (AC) installed in the intermediate loop is opened and residual heat removal commences. The residual heat of the reactor core is removed by natural circulation in both the primary and intermediate-loop coolant, using both the IRACS AC and the RVACS. The blower associated with the AC and the intermediate-loop circulation pump is then started up by the emergency power supply shortly after the occurrence of the event. This results in the forced circulation of both air in the AC and intermediate-loop coolant, and then rapidly cooling the reactor to the cold standby state.

The fuel and cladding peak temperature and CDF for 300 seconds are shown in Figure 16. The fuel peak temperature and the fuel cladding peak temperature of the hottest pin rises to 635°C and 613°C at maximum, meaning there is a sufficient margin to the fuel melting point, thus meeting the “no fuel melting” safety acceptance criterion. The CDF of the hottest pin is  $5.7 \times 10^{-9}$ , which means there is sufficient margin to the safety acceptance criteria,  $CDF < 0.1$ , considering multiple occurrences.

#### ***Failure of a Cavity Can (DBA event)***

If a cavity can is damaged during reactor operation, positive reactivity is inserted and increases reactor power, resulting in a reactor power high signal from the power-range monitor of the safety protection system. This leads to a scram signal and causes the power supplies of the primary- and intermediate-loop circulation EM pumps to switch to the MG-set coastdown power supply. The reflectors are descended and the shutdown rod is inserted, resulting in a rapid decrease in reactor power.

Fuel and cladding peak temperature and CDF for 300 seconds are shown in Figure 17. The fuel peak temperature and the cladding peak temperature of the hottest pin, which provides a sufficient margin to the fuel melt point for the safety acceptance criteria. The CDF for the hottest pin is  $1.7 \times 10^{-8}$  in this event, which provides a sufficient margin to the safety acceptance criterion,  $CDF < 0.1$ , with one occurrence considered. Thus, the 4S design meets the acceptance criterion for fuel integrity.

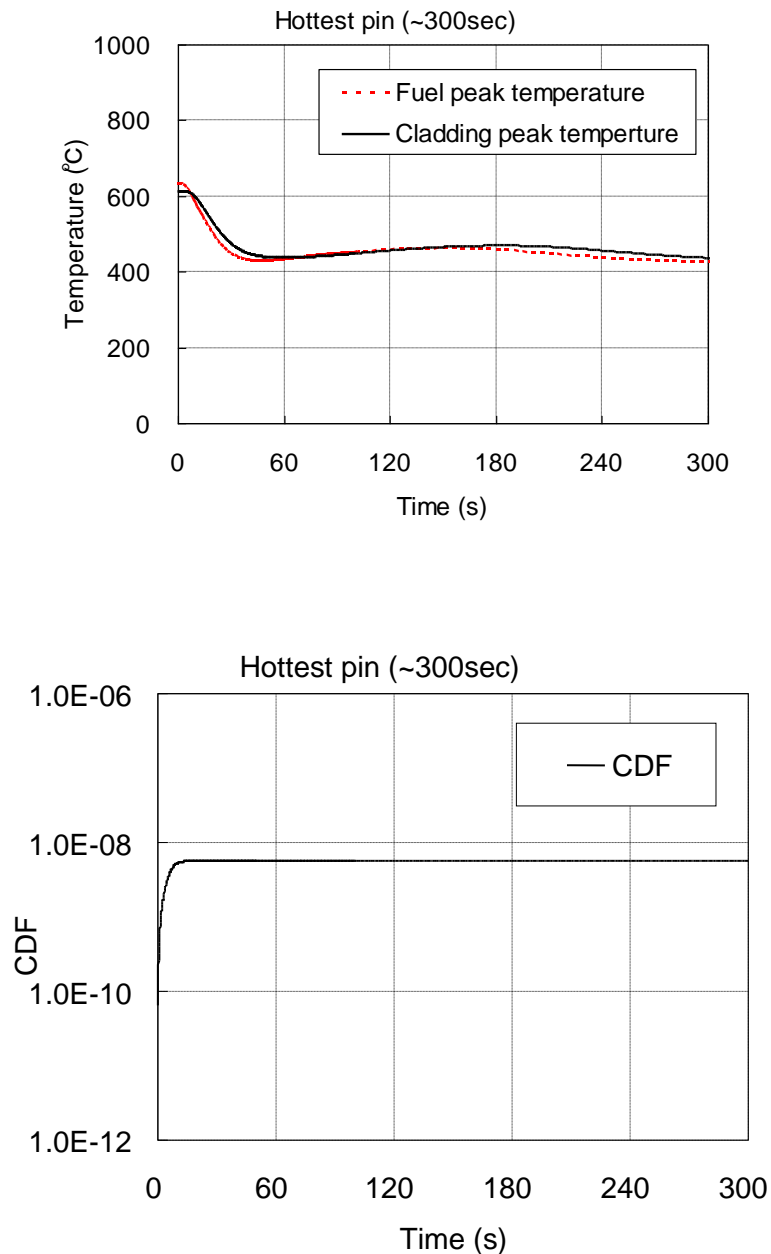

Figure 16 Fuel and Cladding Peak Temperature (upper) and CDF (bottom) for 300 Seconds (Loss of Offsite Power)

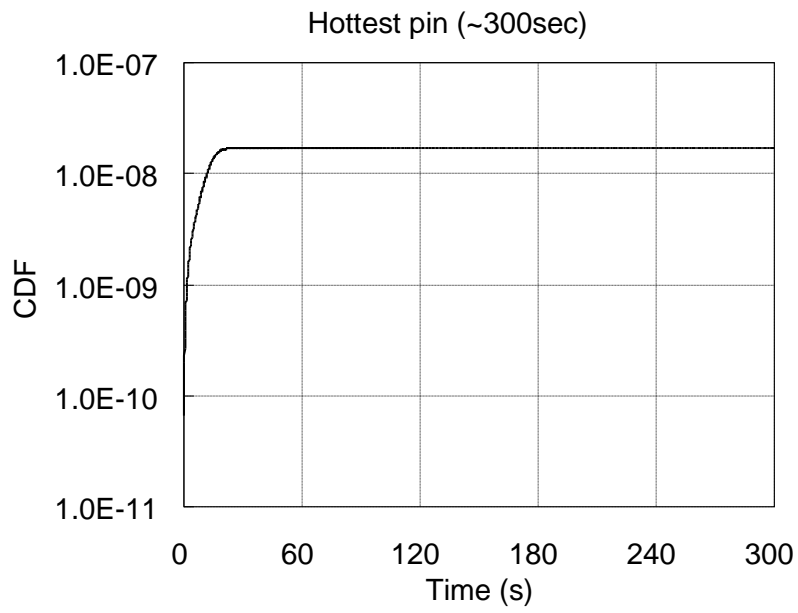
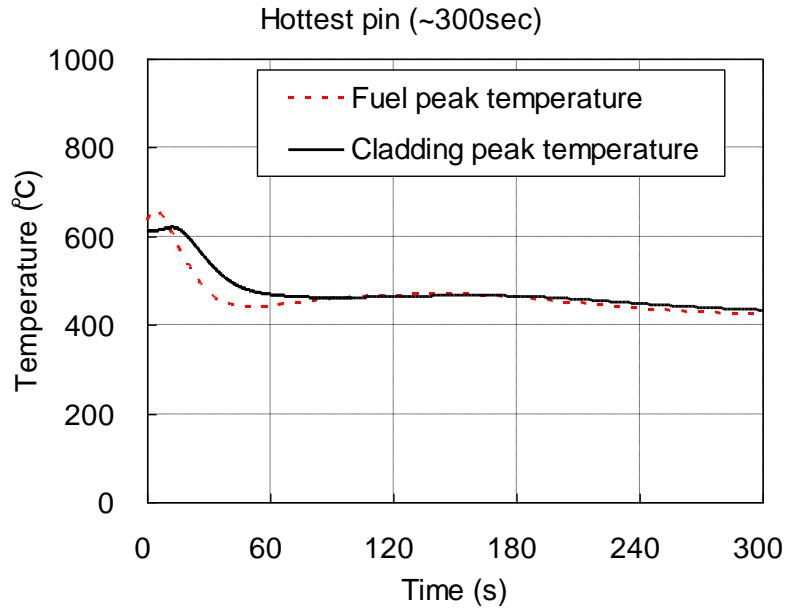

Figure 17 Fuel and Cladding Peak Temperature (upper) and CDF (bottom) for 300 Seconds (Failure of a Cavity Can).

### *Loss of Offsite Power without Scram (ATWS event)*

ULOF event is selected as a typical ATWS case.<sup>2)</sup> After a metric concerned with safety design is defined as performance factor, Phenomena Identification Ranking Table (PIRT) is produced in order to select the plausible phenomena that affect the metric. (CDF for integrity fuel cladding and keeping coolable geometry) Then a sensitivity analysis is performed for the parameters related to the selected plausible phenomena. Finally, the metric is evaluated with statistical methods whether it satisfies the given safety acceptance criteria.

Cladding peak temperature and CDF in ATWS statistical analysis are shown in Figure 18. The CDF for the cladding is used as the metric, and the statistical estimation of CDF with the one-sided upper tolerance limit of 95 percent probability at a 95 percent confidence level has been obtained within the safety acceptance criterion,  $CDF < 0.1$ . In this result, the upper tolerance limit of 95/95 level of cladding temperature and CDF are  $798^{\circ}\text{C}$  and 0.01, respectively. The result shows that the 4S safety performance is acceptable in the ULOF event.

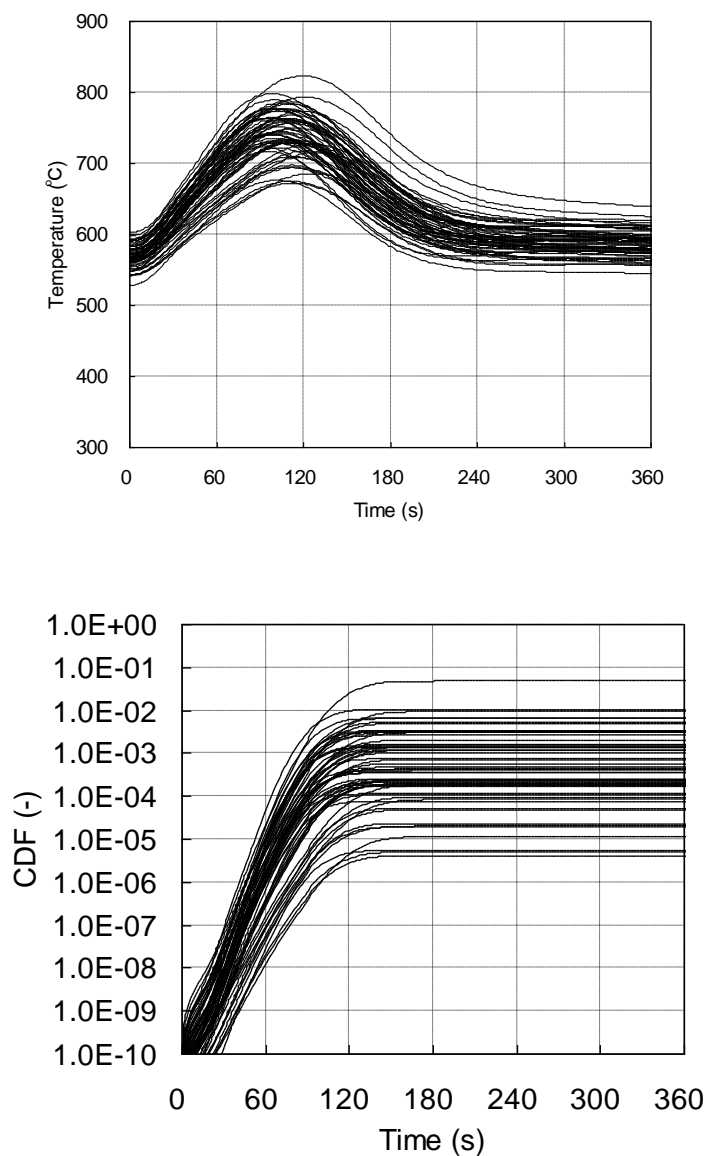

Figure 18 Cladding Peak Temperature and CDF (ATWS Statistical Analysis).



### ***Safety feature related to Fukushima-Daiichi Nuclear Power Plant Accident***

The 4S has a walk-away safety feature related to Fukushima-Daiichi Accident as follows.

#### Station black out (SBO)

Core damage is avoidable without any emergency power supplies by passive decay heat removal with natural circulation (No need for pump operation). There is no limitation to the duration.

#### Spent fuel pool

No need for spent fuel pool due to one year cooling in the reactor vessel after the 30 years' operation, and then stored in dry cask for the 10MWe-4S.

#### Final heat sink in emergency situations

Air is the final heat sink (RVACS and/or IRACS) which does not need water and any emergency power (passive decay heat removal system).

#### Containment system reliability

Containment system consists of top dome and guard vessel.

#### Earthquakes

Reactor building is supported by seismic isolator.

#### Tsunami / Flood

The 4S has redundant shutdown system and passive decay heat removal system without external power supply and emergency power system. Reinforced reactor building is protected from massive water invasion by its water-tightness.

#### Aircraft Hazard

The 4S is constructed underground.

#### Reference

- 1) U.S. NRC Regulatory Guide 1.157, "Best-Estimate Calculations of Emergency Core Cooling System Performance," May, 1989.
- 2) K. Ishii et. al., "Development of 4S and Related Technologies (3) Statistical Evaluation of Safety Performance of 4S on ULOF Event", International Congress on Advances in Nuclear Power Plants (ICAPP 09), Tokyo, May 10-14, 2009.

## 5. Fuel and Fuel Cycle

### SUMMARY FOR BOOKLET (optional)

The 4S reactor can be applied to either once-through fuel cycle scheme or closed fuel cycle scheme. It mainly depends on user country's fuel cycle policy.

In the case of once-through fuel cycle scheme, spent fuel after 30 years' operation is cooled in the reactor vessel for one year and temporary stored in dry cask for the 10MWe-4S. Then, it is eventually shipped to a permanent repository.

In the case of closed fuel cycle scheme, spent fuel can be economically reprocessed by pyroprocess since it is metal fuel, and is re-fabricated as fresh fuel for recycling use. The high level wastes from pyro-reprocessing would be ceramic waste of used salt and metal waste of metal fission products and cladding, which would be contained in a kind of canister for final disposal.

#### 5.1. Fuel Cycle Options

The 4S reactor can be applied to either once-through fuel cycle scheme or closed fuel cycle scheme. It mainly depends on user country's fuel cycle policy. In the case of once-through fuel cycle scheme, spent fuel after 30 years' operation is cooled in the reactor vessel for one year and temporary stored in dry cask for the 10MWe-4S. Then, it is eventually shipped to a permanent repository. In the case of closed fuel cycle scheme, spent fuel can be economically reprocessed by pyroprocess since it is metal fuel, and is re-fabricated as fresh fuel for recycling use. The high level wastes from pyro-reprocessing would be ceramic waste of used salt and metal waste of metal fission products and cladding, which would be contained in a kind of canister for final disposal. Toshiba Energy Systems and Solutions Corporation has been developing the recycling technologies since 1980s.<sup>1)</sup>

In either case, spent fuel needs to be taken out from the reactor vessel. However, since the refueling interval for the 10MWe-4S is 30 years, the fuel handling system is not usually located at the reactor site. When it is needed, the temporal fuel handling system, which is shown in Figure 12, is set at the reactor site.

Failed fuel during operation can be detected by continuously monitoring the cover gas radioactivity in the reactor vessel.

#### 5.2. Resource Use Optimization

The major provisions of the 4S reactor for resource use optimization are as follows.

- Simplified plant design contributes to waste reduction during operation and decommissioning.
- Low maintenance requirement using no-moving parts component such as the EM pump contributes to low maintenance costs/labours and low waste amount.
- Reduced emergency planning zone contributes to accident management burden and/or cost such as for evacuation.
- Nuclear fuel utilization can be significantly improved by fuel recycling.

#### Reference

- 1) K. Arie et. al., "A Strategy for Advanced Fuel Cycle Deployment", International Congress on Advances in Nuclear Power Plants (ICAPP 06), Reno, June 4-8, 2006.

## ***6. Safeguards and Physical Security***

### **SUMMARY FOR BOOKLET (optional)**

Below-grade siting helps to protect the reactor building from external hazard such as missile or airplane impact. Embedding the whole reactor underground is one of the most natural and substantial methods of physical protection against unauthorized access and external missiles. Other features of the 4S contributing to an enhanced physical protection are as follows:

- Long refueling interval of 30 years
- The reactor operates completely sealed.
- The operation is automatic without the need of operator actions. For example, the reactor is operated using a system of pre-programmed movable reflectors.
- “Continuous monitoring” rather than “active operation” for plant/component conditions and unauthorized access

#### **6.1. Safeguards**

Below-grade siting helps to protect the reactor building from external hazard such as missile or airplane impact (see Figure 1). Embedding the whole reactor underground is one of the most natural and substantial methods of physical protection against unauthorized access and external missiles. Other features of the 4S contributing to an enhanced physical protection are as follows:

- Long refueling interval of 30 years
- The reactor operates completely sealed.
- The operation is automatic without the need of operator actions. For example, the reactor is operated using a system of pre-programmed movable reflectors.
- “Continuous monitoring” rather than “active operation” for plant/component conditions and unauthorized access

As a result, only five guard personal per shift is needed.

#### **6.2. Security**

Same as above.

## ***7. Project Delivery and Economics***

### **SUMMARY FOR BOOKLET (optional)**

To be a viable option for power generation in remote areas, the 4S should provide a competitive cost of electric power. The target plant construction cost is \$10,000/kWe and the O&M cost of 4.5¢/kWh. The target construction cost could be achieved by the simplified and standardized design, shop fabrication, modular construction, short construction time, and mass production. The O&M cost could be achieved by long-refuelling interval, and low-maintenance requirements of components such as the EM pump.

Toshiba Energy Systems & Solutions Corporation is continuing to seek customers.

To be a viable option for power generation in remote areas, the 4S should provide a competitive cost of electric power. The target plant construction cost is \$10,000/kWe and the O&M cost of 4.5¢/kWh. The target construction cost could be achieved by the simplified and standardized design, shop fabrication, modular construction, short construction time, and mass production. The O&M cost could be achieved by long-refuelling interval, and low-maintenance requirements of components such as the EM pump.

Toshiba Energy Systems & Solutions Corporation is continuing to seek customers.